



CONNECT AND PROTECT

Hydraulic & Manual Tools

Flexible Busbar and Copper Busbar Manipulation and Transformation Solutions

nVent

ERIFLEX

Manual Flexibar Work Center

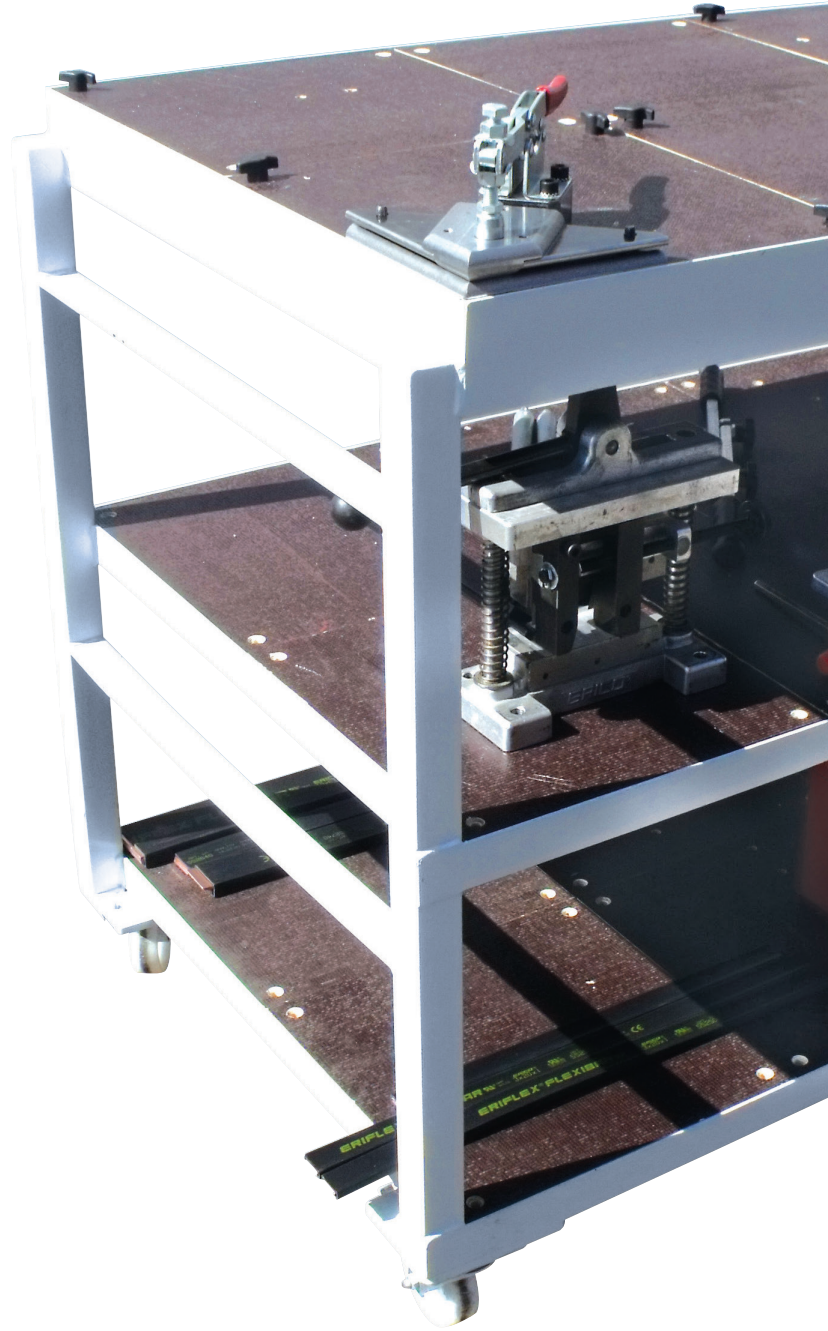

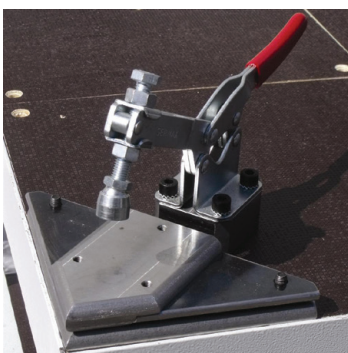
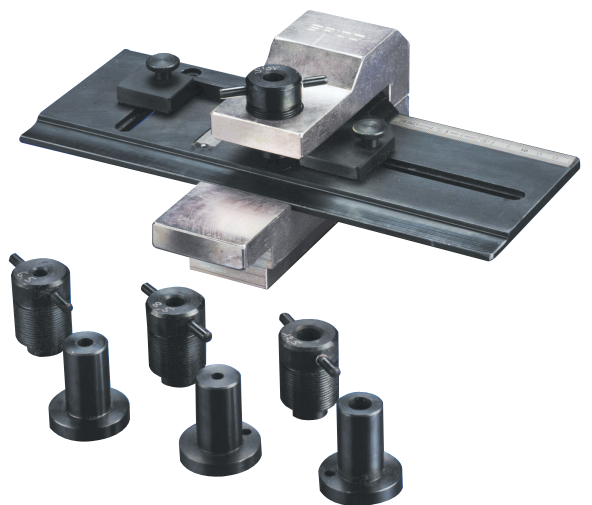
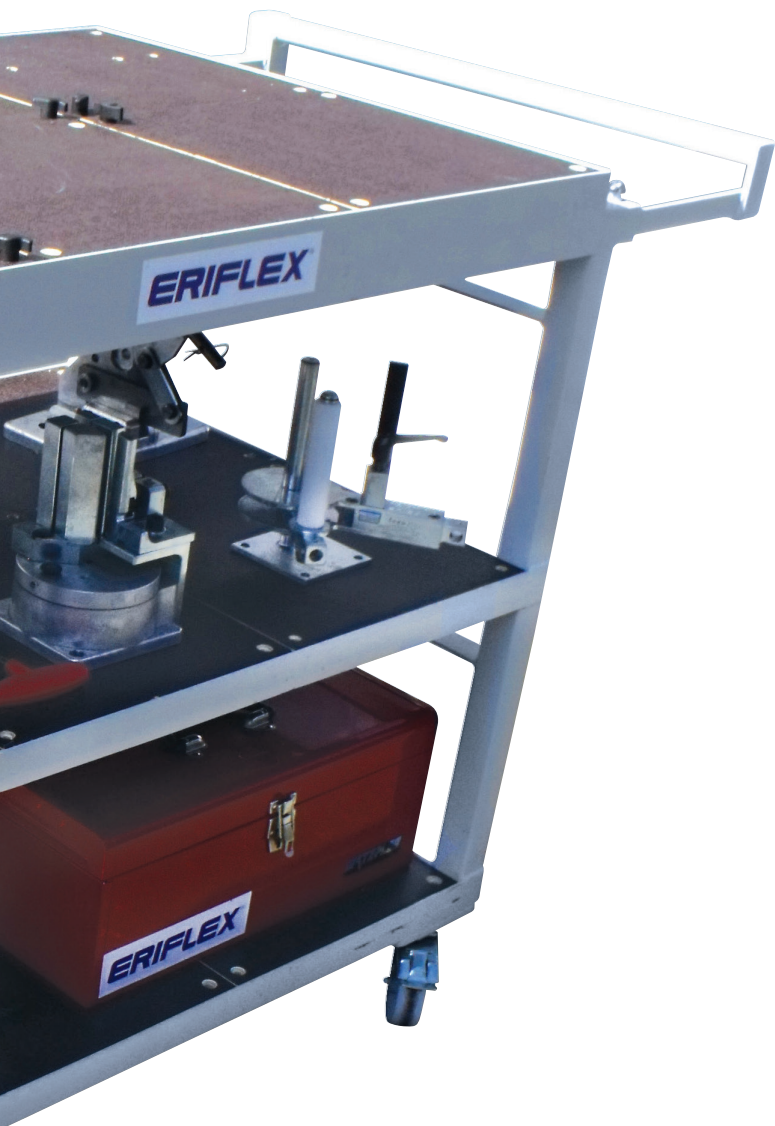

Manual Flexibar Work Center (MFWC)

MODULAR TABLE FOR FLEXIBAR MANUAL TOOLS

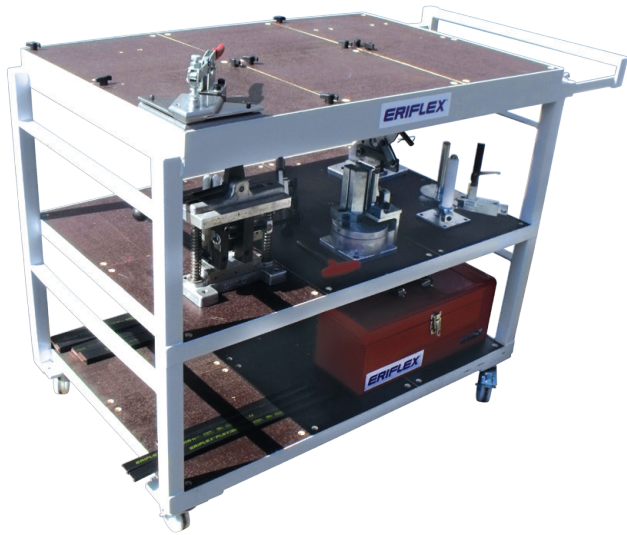

FEATURES

- Modular table with large work surface and storage for manual Flexibar tools
- Tools can be fixed directly to interchangeable tiles, allowing tools to be quickly moved from one level to another
- Non-slip bakelite coated plywood tiles fix into place with wing knobs included
- Includes Flexibar Small Bending and Folding Tool
- Forklift rail, locking directional wheels and built-in handles provide easy mobility
- Built-in handle is extendable to accommodate long pieces of Flexibar

SPECIFICATIONS

| | |
|------------------------------------|--------|
| Part Number | MFWC |
| Article Number | 558940 |
| Unit Weight | 95 kg |
| Certifications | RoHS |
| Standard Packaging Quantity | 1 pc |

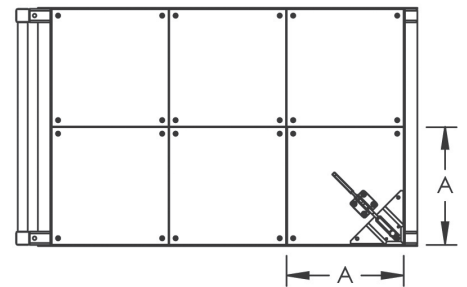
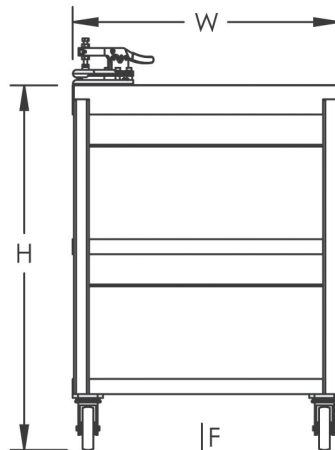
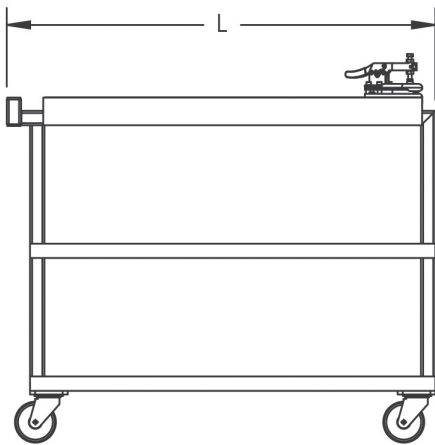

Flexibar Folding Tool MFF

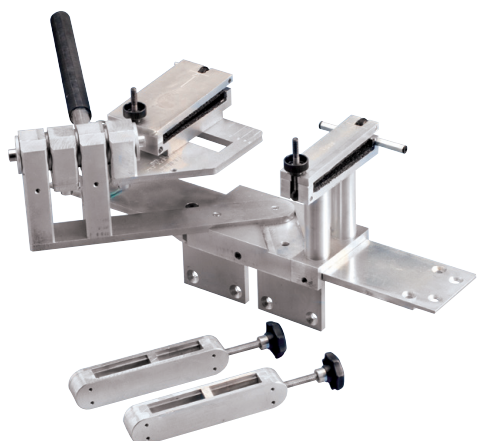

- Flexibar folds up to 10x120x1/12x100x1
- Folds quickly without insulation damage
- Multiple bending shapes: L - U - Z
- Easy to produces many shapes and sizes
- Significantly reduces Flexibar scrap
- Limits heavy Flexibar handling
- Quick and easy tool set up
- Universal tool for workshop or jobsite
- For Flexibar only

| Article N° | Description |  |  |
|------------|---------------------------|---|---|
| 558930 | Flexibar Folding Tool MFF | 1 | 20 kg |

FLEXIBAR FOLDING PROCESS

Overall dimensions: L 600 x W 305 x H 305 mm

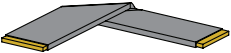
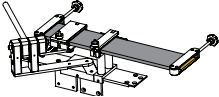
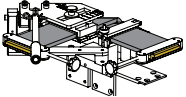
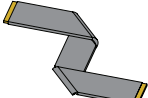
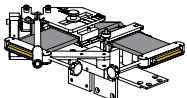
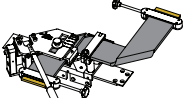
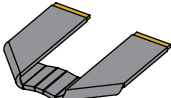
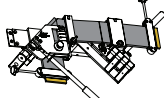
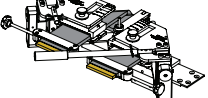
| L Shape | | | Tool (s) to Use |
|---|---|--|-----------------|
|  |  |  | |
| Z Shape | | | 558930 x1 |
|  |  |  | |
| U Shape | | | Tool (s) to Use |
|  |  |  | |
| | | | 558930 x1 |
| | | | 558931 x1 |

FLEXIBAR LONG & LARGE QUANTITIES

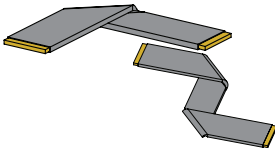
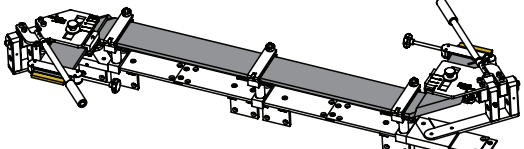
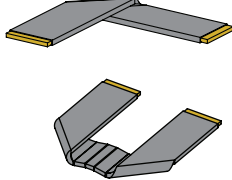
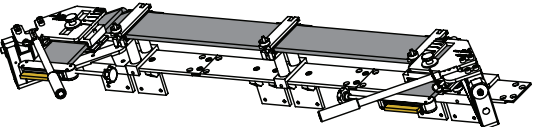
| L + Z Shape | | Tool to Use | L | Z |
|---|--|-----------------|----|----|
|  |  | | | |
| | | 558932 | x2 | x1 |
| | | 558933 | x2 | x1 |
| L + U Shape | | Tool (s) to Use | L | V |
|  |  | | | |
| | | 558931 | | x1 |
| | | 558932 | x2 | x2 |
| | | 558933 | x2 | x2 |

Flexibar Folding Tool

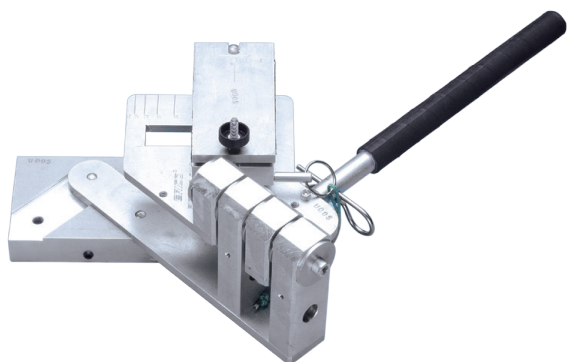

FLEXIBAR FOLDING TOOL U-SHAPE - MFFU

- Accessory to the MFF tool
- Use with the MFF tool for U-shape folding

Overall dimensions: L 355 x W 305 x H 205 mm

| Article N° | Description |  |  |
|------------|------------------------------------|---|---|
| 558931 | Flexibar Folding Tool U-Shape MFFU | 1 | 9 kg |

FLEXIBAR FOLDING TOOL FIXED VICE - MFFV

- Accessory to the MFF tool
- Supports long Flexibar
- Allows easy folding of long Flexibar

Overall dimensions: L 170 x W 125 x H 205 mm



| Article N° | Description |  |  |
|------------|---------------------------------------|---|---|
| 558932 | Flexibar Folding Tool Fixed Vice MFFV | 1 | 2,2 kg |



FLEXIBAR FOLDING TOOL RAIL - MFFR

- Accessory to the MFF tool
- Assists with the assembly of the MFF and MFFU tools for long Flexibar
- Fix the folding tool to the workbench or vice

Overall dimensions: L 600 x W 100 x H 120 mm

| Article N° | Description |  |  |
|------------|---------------------------------|---|---|
| 558933 | Flexibar Folding Tool Rail MFFR | 1 | 6,4 kg |

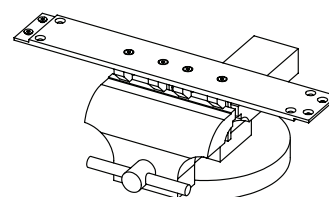
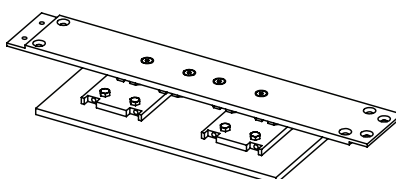
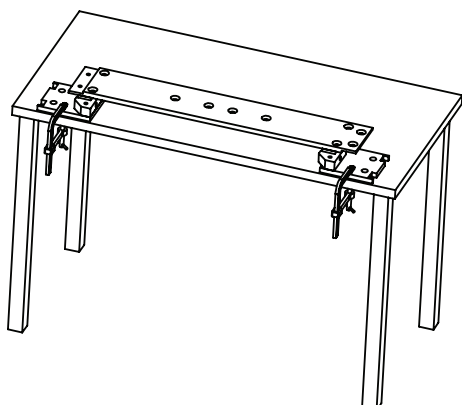

Flexibar Folding Tool

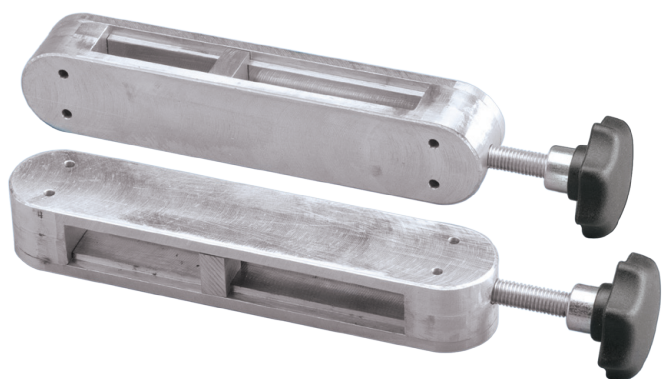

FLEXIBAR FOLDING TOOL CLAMP - MFFC

- Accessory to the MFF tool
- Prevents any Flexibar laminates from sliding during the folding operation
- Allows for quality palms on Flexibar ends
- Helps with insulation stripping on large Flexibar sizes

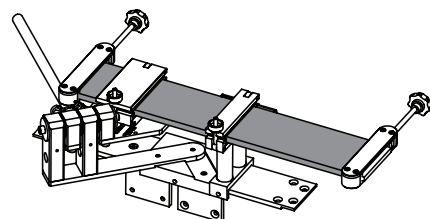
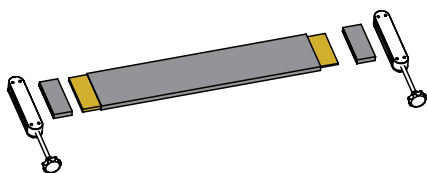
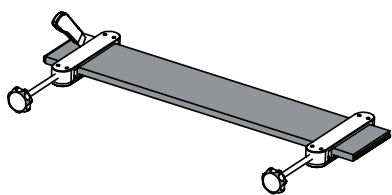

Overall dimensions: L 240 x W 50 x H 50 mm



| Article N° | Description | Flexibar |  |  |
|------------|--------------------------------------|-----------|---|---|
| 558934 | Flexibar Folding Tool Clamp 63 MFFC | 20 -> 63 | 2 | 0,45 kg |
| 558935 | Flexibar Folding Tool Clamp 120 MFFC | 20 -> 120 | 2 | 0,535 kg |



Flexibar Bending Tool HFBT



- Flexibar bends up to 10x120x1/12x100x1
- Bends quickly without insulation damage
- Limits heavy Flexibar handling
- Universal tool for workshops or jobsites
- Angle adjustment up to 180°
- Bending radius: 10 mm
- Compact tool in steel case

| Article N° | Description |  |  |
|------------|-----------------------|---|---|
| 558920 | Flexibar Bending Tool | 1 | 7 kg |

On Workbench

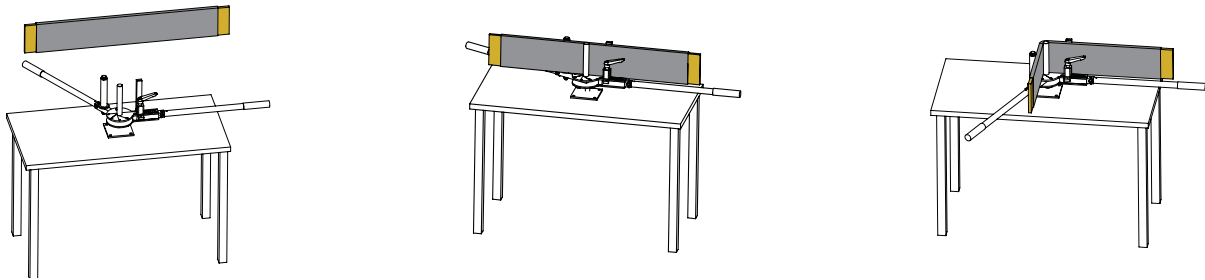

On Jobsite

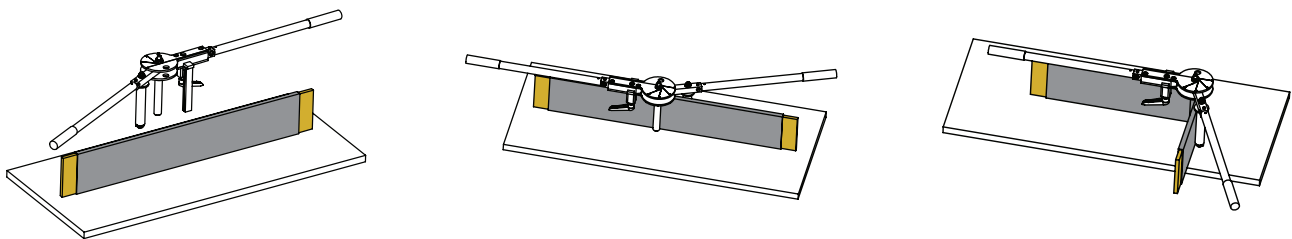

Tool Capability



Flexibar Manual Tools

A COMPLETE RANGE OF USEFUL HAND TOOLS FOR FLEXIBAR, BRAIDS AND DIN PROFILES

Cutting, bending, drilling, twisting: nVent ERIFLEX offers a complete manual tool range.



TWISTING TOOL



STRIPPING TOOL



SHEARING TOOL



BENDING TOOL

EVERY TOOL CAN BE PURCHASED SEPARATELY - SEE PAGES 19-21

FLEXIBAR WORKBENCH

A COMPLETE SET OF USEFUL HAND TOOLS FOR FLEXIBAR.



Overall dimensions: L 500 x W 500 x H 290 mm

- A. Cutting tool
 - Specifically designed for cutting Flexibar up to 5x32 cm
- B. Stripping tool
 - Cut all 4 sides of insulation in one operation without marking the copper.
- C. Bending tool
 - Simple hand operated bending tool. Does not damage insulation.
- D. Twisting tool
 - Used in conjunction with bending tool. This simple tool facilitates plane change
- E. Cutter
 - Stripping knife with interchangeable blades
- F. Instruction
 - Clear instruction sheet for the use of the tools.

| Article N° | Description |  |  |
|------------|------------------|---|---|
| 559149 | Workbench - MFTK | 1 | 35 kg |

Flexibar Manual Tools

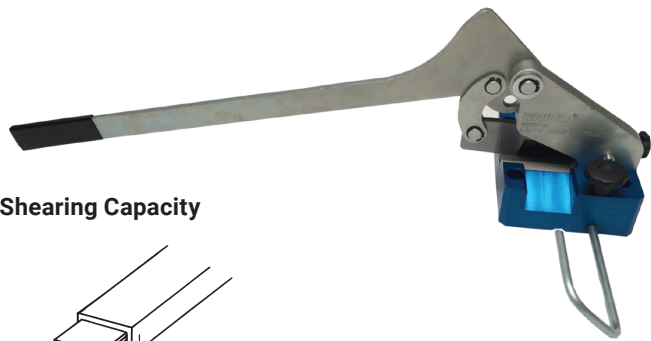

Shearing Capacity

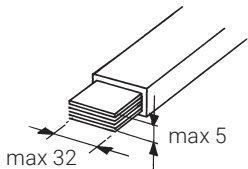

Flexibar 5 x 32 x 1 maximum

WARNING: Cutting solid bars will damage the tool

SHEARING TOOL

- Cuts quickly and accurately without burrs or deformation
- Cuts with the insulation on – without any damage
- Graduated endstop
- Cost-effective
- Spare blade MFCB



| Article N° | Description |  |  |
|------------|---------------------------------------|---|---|
| 559146 | MFSHT-2 Flexibar Manual Shearing Tool | 1 | 6 kg |
| 559147 | Replacement Blades for MFSH | 1 | 0.5 kg |



BENDING TOOL

- Bends quickly without insulation damage
- Manual saw guide included
- Adjustable angle up to 120°
- Bending radius: 5 mm
- Maximum capacity: Flexibar 10 x 100 x 1

Overall dimensions: L 170 x I 150 x H 220 mm

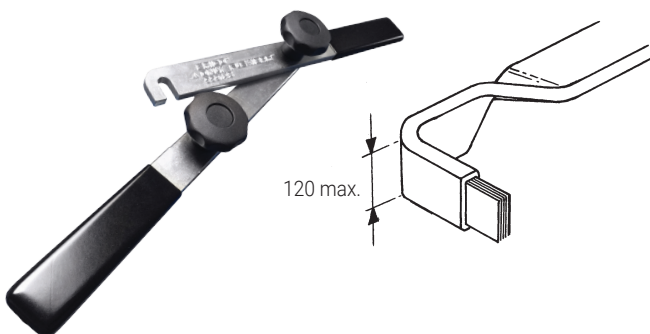

| Article N° | Description |  |  |
|------------|-------------------------------------|---|---|
| 559145 | MFBT-2 Flexibar Manual Bending Tool | 1 | 7 kg |



TWISTING TOOL

- Unlimited possibilities of twisting or changing plane. Designed to be used with the bending tool

Overall dimensions: L 560 x I 150 x H 70 mm

| Article N° | Description |  |  |
|------------|--------------------------------------|---|---|
| 559148 | MFTT-2 Flexibar Manual Twisting Tool | 1 | 2.5 kg |

Flexibar Manual Tools

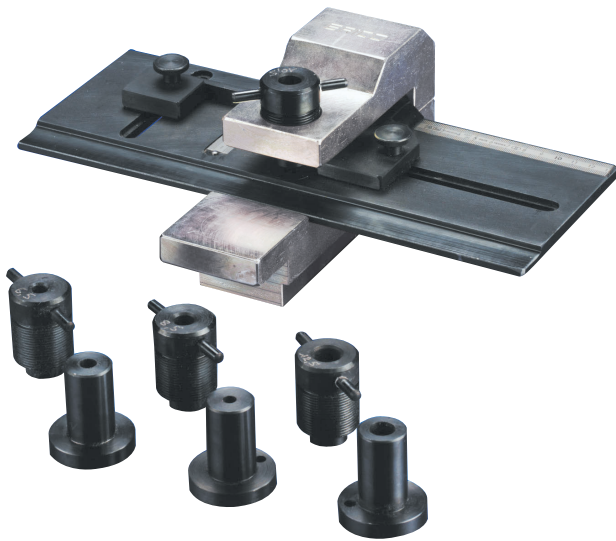

NVENT ERIFLEX FLEXIDRILL DRILL GUIDE

- Multi-diameter, multi-distance between centers.
- This guide facilitates the drilling of one or more holes of various diameters at different distances between centers.
- Drill guide inserts:
 - 6,5 mm / 8,5 mm / 10,5 mm / 12,5 mm (558600)
 - 5/16" Die Set - 1/4" Bolt, 3/8" Die Set - 5/16" Bolt, 17/32" Die Set - 7/16" Bolt, 9/16" Die Set - 1/2" Bolt (558601)

Overall dimensions: L 560 x l 150 x H 70 mm

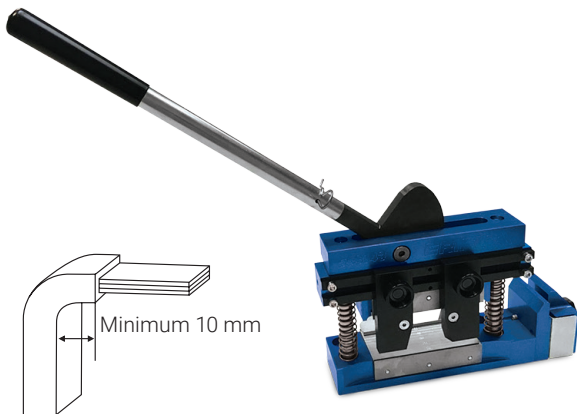

| Article N° | Description |  |  |
|------------|----------------------------------|---|---|
| 558600 | nVent ERIFLEX Flexidril | 1 | 9.5 kg |
| 558601 | nVent ERIFLEX Flexidril Imperial | 1 | 9.5 kg |



STRIPPING TOOL

- Quick & simple stripping of Flexibar from 9 up to 120 mm
- Cuts all of 4 faces of the insulation in a single operation without damaging the copper.
- Allows stripping on short length
- Aluminium cast body, four holes for fixing

Overall dimensions: L 220 x W 100 x H 250 mm

| Article N° | Description |  |  |
|------------|--|---|---|
| 559143 | MFST-2 Flexibar Stripping Tool | 1 | 8 kg |
| 559144 | MFST-2 Flexibar Stripping Tool Blade Set | 1 | 1 kg |

STRIPPING KNIFE

- Accurately cuts the Flexibar insulation
- Special sharpening to avoid damaging the conductors
- Highly resistant blade, interchangeable
- Blade protection
- Ergonomic shockproof resin handle



| Article N° | Description |  |  |
|------------|-----------------------|---|---|
| 559050 | Stripping knife - SOK | 1 | 0.062 kg |
| 559060 | Spare blade for SOK | 1 | 0.020 kg |

Flexibar Manual Tools



PUNCHING TOOL & ACCESSORIES

- Works with copper or aluminium busbar and Flexibar
- Punches flat and clean hole edges
- Accurately punches Flexibar in a single operation without marking the copper laminates
- Quick and easy installation
- Quick setup with interchangeable punch and die system
- Large range of round punches and dies available
- Includes adjustable throat depth stop
- Removable handle
- Portable tool can be used on the jobsite or attached to a workbench
- RoHS compliant

| Article No | Part Number | Busbar thickness | Depth | Height | Width |  |
|------------|-------------|------------------|--------|--------|--------|---|
| 559152 | MFPT | 6 mm Max | 240 mm | 450 mm | 110 mm | 15.1 kg |

PUNCHING TOOL & ACCESSORIES

- For use with MFPT Flexibar Punching Tool
- Kit includes one punch, one die, and one ejection stop
- Quick and easy installation
- RoHS compliant



| Article No | Description | Punch Size | Screw Diameter |  |
|------------|---------------|------------|----------------|---|
| 559153 | MFPTPD-M6-14 | 7.0 mm | M6, 1/4" | 0.15 kg |
| 559154 | MFPTPD-M8 | 9.0 mm | M8 | 0.15 kg |
| 559155 | MFPTPD-M10-38 | 11.0 mm | M10, 3/8" | 0.15 kg |
| 559156 | MFPTPD-M12-12 | 13.0 mm | M12, 1/2" | 0.15 kg |

Flexibar Manual Tools

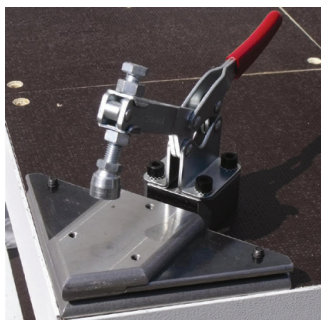

FLEXIBAR SMALL BENDING AND FOLDING TOOL



- Used to ease the process of bending, folding or twisting of Flexibar

| Article N° | Description |  |  |
|------------|-------------|---|---|
| 558945 | SFBF | 1 | 5.1 kg |

MHYFSHT MANUAL HYDRAULIC FLEXIBAR SHEARING TOOL

- Cuts Flexibar quickly and accurately without burrs or deformation
- Cuts through the insulation without damaging it
- Works with all sizes of Flexibar
- Integrated handles allow for easy portability
- Works without electrical or hydraulic power
- Includes two brackets for mounting to workbench
- Strong mechanical assembly
- Replacement blade available
- RoHS compliant



| Article N° | Description |  |  |
|------------|---|---|---|
| 559151 | MHYFSHT - Manual Hydraulic Flexibar Shearing Tool | 1 | 29 kg |

Flexibar Manual Tools

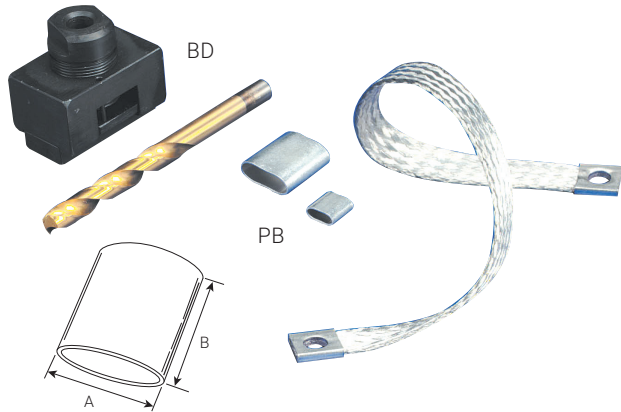

BRAID & CRIMP DRILL TOOL

- BD - Crimp & Braid Drill Tool
 - Comprised of a guide and adapted drill bit.
 - For crimping and drilling of braid terminals Comprise.
- PB Lugs for Flat Braids
 - Tinned annealed copper

| Article N° | Description | Bolts | | |
|------------|--------------|-------|---|----------|
| 558610 | BD 16 - 6,5 | M6 | 1 | 0.653 kg |
| 558640 | BD 16 - 8,5 | M8 | 1 | 0.653 kg |
| 558620 | BD 25 - 11 | M10 | 1 | 0.678 kg |
| 558630 | BD 50 - 12,5 | M12 | 1 | 0.712 kg |

| Article N° | Description | For Flat Braid | A X B | | |
|------------|-------------|--------------------|---------|-----|----------|
| 557180 | PB 16 | FTCB or FRCB 15-16 | 16 x 15 | 100 | 0.004 kg |
| 557190 | PB 25 | FTCB or FRCB 15-25 | 22 x 25 | 100 | 0.010 kg |
| 557380 | PB 50 | FTCB or FRCB 15-50 | 30 x 30 | 100 | 0.017 kg |

CUTTING & PUNCHING TOOL FOR DIN PROFILES

- Punches slots and cuts DIN rail without burrs or deformation
 - Punches horizontal and vertical slots
 - Works with five different types of DIN rail and M6 threaded rod
 - Includes ruler, guide and end stops
 - RoHS compliant

Overall dimensions: L 165 x W 100 x H 200 mm

Lever: 630 mm



| Article N° | Description | | |
|------------|-----------------|---|-------|
| 559142 | DIN rail Cutter | 1 | 13 kg |